

# DELTA MEMBRANE SYSTEMS LTD BASEMENT PUMP & DRAINAGE

February 2020



# CONTENTS

---

DELTA MEMBRANES	03
SERVICES	04
BASEMENT PROTECTION	05
GROUND & SURFACE WATER	06
GROUND & SURFACE WATER - DRAINAGE	08
DUAL V3	010
DUAL V3.1	012
DUAL V4	014
DUAL V6	016
800 SERIES GROUND & SURFACE WATER STATIONS	018
1000 SERIES GROUND & SURFACE WATER STATIONS	020
FOUL WATER PUMP STATIONS	022
FOUL V3	024
800 SERIES FOUL WATER STATIONS	026
1000 SERIES FOUL WATER STATIONS	028
ALERTMAXX2	030
POWERMAXX2	032
HI-POWERMAXX	033
ANCILLARY PRODUCTS & MAINTENANCE	034
'FREE LIME' RISK	035

---

# DELTA MEMBRANES



Delta Membrane Systems Limited is the leading Type C Cavity Drain Membrane Manufacturer in the United Kingdom. Our extensive range of waterproofing and damp proofing products are suitable for basement drainage and structural waterproofing (both for new build and existing structures) and in flood resilience projects.

Installing a Delta Membrane System offers complete protection to structures from ground water ingress and contaminates. Our products comply with British Standard BS 8102:2009 and are BBA Certified. Our dedicated Technical Team offer knowledge and experience in waterproofing design solutions and can provide on-site assistance and advice throughout a project.

BS 8102:2009 (Code of Practice for Protection of Below Ground Structures Against Water from the Ground) recommends that every Design Team should incorporate a Waterproofing Design Specialist.

Delta Membrane Systems Limited has a dedicated team of Waterproofing Design Specialists. Our trusted Technical Team offer knowledge and experience and are able to provide expertise in structural waterproofing. As a Waterproofing Specialist Manufacturer, we work with architects, surveyors, contractors and engineers alike to provide a design service which complies with BS 8102:2009 and offers the highest level of technical expertise and assurance.



# SERVICES

Delta Membrane Systems Limited provides a full range of waterproofing solutions suitable for all new, retrofit and refurbishment construction. With over 125 years of manufacturing experience, Delta is an impeccable partner on every project. Our skills have been mastered through experience in the waterproofing industry. Delta's trusted Technical Team will offer assistance from concept to completion. Our hands on approach and knowledge is what sets us apart.



## DESIGN SUPPORT

- Architecture knowledge
- Concept and waterproofing solutions
- Advice on design and best practice
- Custom solutions, as each project is unique in requirements
- Qualified CSSW staff (named on the Waterproofing Design Register)



## SPECIFICATION SUPPORT

- Detailed drawings including CAD
- Watertight and locking down structure concepts
- Specifications
- BIM
- NBS Plus
- RIBA Product Selector



## SITE SUPPORT

- Training and guidance offered at every step
- Technical Team attendance at site meetings
- Knowledge and experience
- Troubleshooting solutions



# BASEMENT PROTECTION



One of the main design considerations when designing a Cavity Drain System is to consider managing the collection and discharge of ground and/or foul water.

The majority of projects will require a collection sump + pump to automatically manage the evacuation of water ingress. A sump + pump solution will require mains power to operate.

Peace of mind is offered with the MaxxFamily product range. The AlertMaxx2 is a high level water alarm and monitoring system which will predictively alert a homeowner when there is a potential fault or service required to the sump pump. Our extensive range of battery back-ups offer unrivalled technology and will keep the sump pump working in the event of power failure.

The number of pump systems required for each project will (in part) depend on the overall basement size, perimeter and also the method of drainage – Delta Channel, Modular or a combination of both.

External surface water from light-wells, courtyards and terraces may be drained into the ground water sump, providing the area of external surface water collection does not exceed 12m<sup>2</sup> to each sump – if the external area is greater, advice should be sought from the Delta Technical Team.

For each sump system, the recommendation is for two pumps in case of failure of the duty pump. In the event of failure of the duty pump, the secondary back up pump will take over, therefore significantly reducing the risk of potential flooding. In addition, a minimum industry standard would be to include a high level alarm such as the Delta AlertMaxx2 and power back up system such as Delta PowerMaxx in case of mains power failure. Again reducing the risk of potential flooding to the basement.



# GROUND & SURFACE WATER

## GROUND & SURFACE WATER

A range of pump stations designed to collect ground and/or surface water from the smallest domestic basement through to large commercial projects.

Our range of products have been designed specifically for the application and brings the technology of waterproofing and discharging water from properties under one responsibility, fully integrated and co-ordinated.

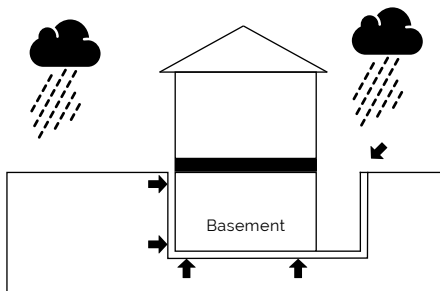

## GROUND WATER

- Ground water collects or flows beneath the Earth's surface, filling the porous spaces in soil, sediment and rocks, originating from rain, melting snow and ice and is the source of water for aquifers, springs and wells.
- The basement structure should offer the primary resistance to passage of water.

## PLEASE NOTE

For any calculation, detailed reference should be made to the relevant British/European Standard.

## CALCULATING FLOW RATES (GROUND WATER)

- It is virtually impossible to calculate water ingress through a structure, however, we need to make some assumptions and based on our experience we allow 0.001l/s/m<sup>2</sup> of basement slab and walls and then allow a safety factor of 5. However, if the basement pumps are monitored by AlertMaxx2 & SideWinder we can build up a dataset for water ingress and make recommendations if and when necessary.

## CALCULATING GROUND WATER INGRESS

- It is very difficult to obtain data for water ingress, we need to assume...
- For basements above the water table, assume 0.1l/s per 100m<sup>3</sup> basement wall and floor area (or 0.001l/s/m<sup>2</sup>). Multiply by a factor of safety of 5.
- For basements below the water table assume 0.2l/s per 100m<sup>3</sup> basement wall and floor area (or 0.002l/s/m<sup>2</sup>). Multiply by a factor of safety of 5.

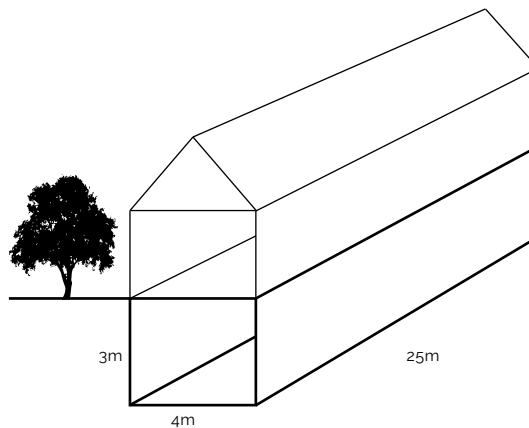

Slab = 25m x 4m = 100m<sup>2</sup>  
 Wall 1 = 25m x 3m x 2no = 150m<sup>2</sup>  
 Wall 2 = 3m x 4m x 2no = 24m<sup>2</sup>  
 Total area = 274m<sup>2</sup>  
 Multiply total area by flow rate and factor of safety  
 =274m<sup>2</sup> x 0.001l/s/m<sup>2</sup> x 5 = 1.37l/s

## CALCULATING FLOW RATES (SURFACE WATER)

- When selecting a pump station for collecting & discharging surface water we take into account a 5 minute storm event and the storage required for 24 hours, we always use a 500 year return period for basement applications and 24 hour storage as they are considered critical. *Battery backups can be used instead of physical storage.*

Example : 25m<sup>2</sup> surface water application i.e. patio or small rear roof elevation

Flow rate: Area x l/s/m<sup>2</sup> = 1.6l/s

5 minute storage: Area x l/s/m<sup>2</sup> x 5 minutes

24 hour storage: Area x 0.11

## CALCULATING SURFACE WATER FLOW RATES & STORAGE

Design intensity for London based on BS EN 752 (2008)

Return period	l/s/m <sup>2</sup>	mm/hour
1 year	0.016	57.6
5 years	0.024	86.4
50 years	0.040	144.0
500 years	0.064	230.4

## WHY FOUL & GROUND WATER SHOULD NEVER BE MIXED

1. Foul gas will be able to migrate into the cavity spaces behind the membrane and will be able to escape into the building at the top edges of the membrane sheet, which must be left unsealed.
2. In the event of a pump station becoming inoperative, continual use of the sanitary appliances may result in the foul level rising above the normal operating level to the extent that effluent would back-fill the cavity drainage system and eventually escape into the cavities, resulting in contamination of floor construction.

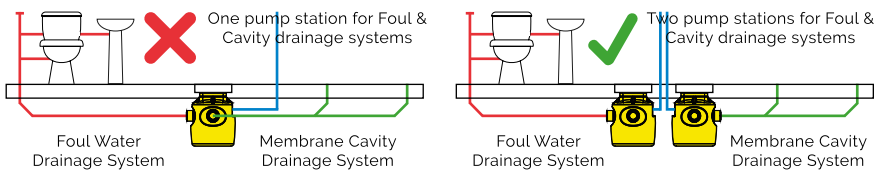

## BASEMENT WITHOUT FLOOD PROTECTION



- If the sewer becomes surcharged and if the road surface floods, water will back-up in the house drain and flood the basement.
- If the sewer causes the surface of the road to flood, then the level of the flood water in the basement will reach the same level.

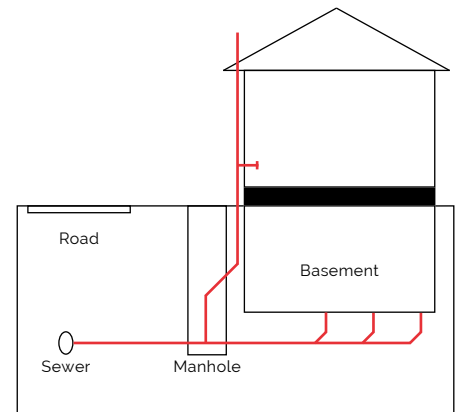

## FLOOD PROTECTION MEASURES

- A pump station with an anti-flooding loop in the discharge pipe is the best method in accordance with BS12056-4.
- If the sewer becomes surcharged and if the road surface floods, the basement will remain safe.
- Flood water cannot pass over the top of the anti-flooding loop.
- Benefits:
  - Flood protection is not reliant on valves which may leak and won't prevent odours travelling back into the property.
  - The pumped drainage system will remain operational during flooding.

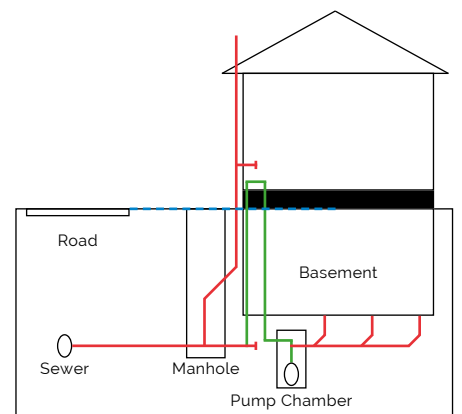

# GROUND & SURFACE WATER - DRAINAGE



## PERIMETER DRAINAGE CHANNEL

Channel typically laid level in a rebate in the structural slab. As the name suggests it is run around the perimeter of the basement, but can also be installed across the basement to improve drainage. The maximum distance from the end of channel to the sump is 25 linear meters, therefore one sump can be used for a 50m linear run where the sump is installed centrally.

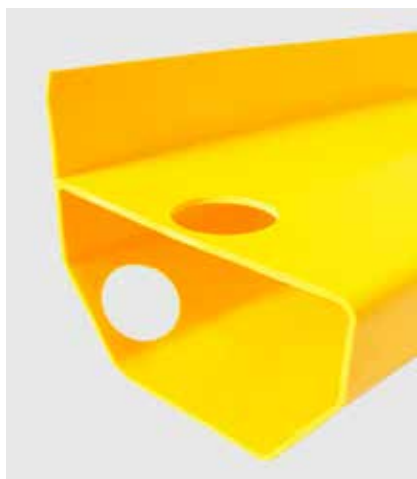
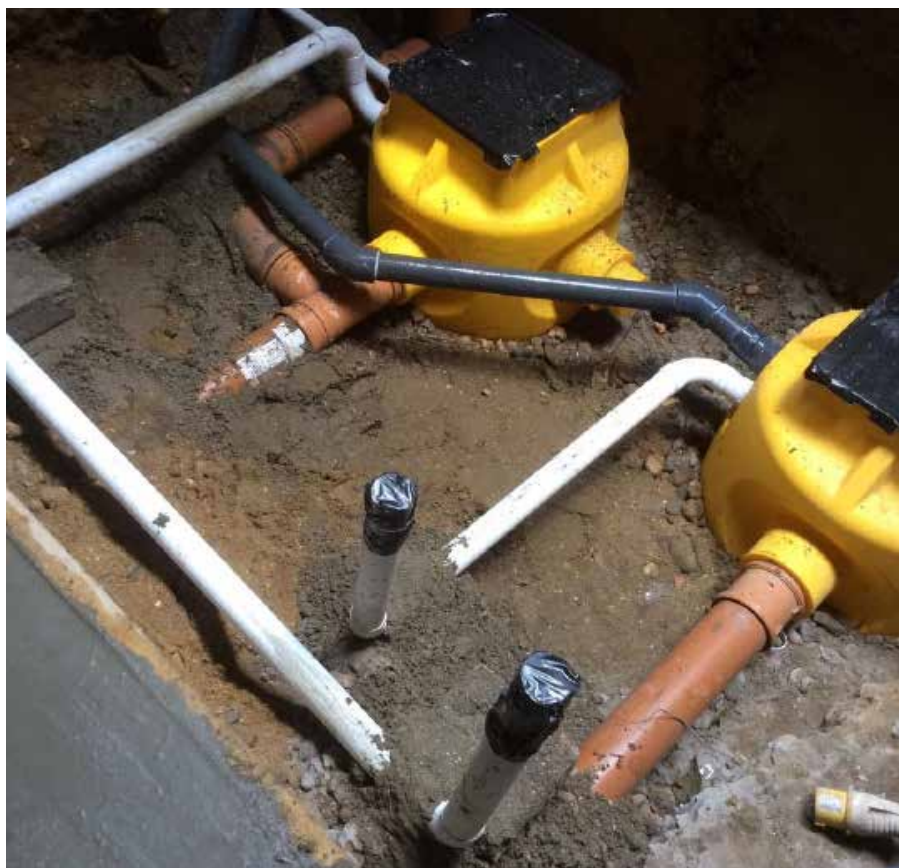

## MODULAR DRAINAGE

110mm drainage pipe laid below or in the slab to a fall of 1:100. One pump station can serve areas over 200m<sup>2</sup>. Typically one drainage point is required every 12m<sup>2</sup> of basement slab area.



## SURFACE WATER LIMITS FOR GROUND WATER SUMPS

- Where rainwater from a total surface area exceeding 12m<sup>2</sup> is to be pumped it is recommended this water is drained to a dedicated pump station.

## CONSTANT RAINFALL

- Constant rate rainfall intensity for an event of 5 minutes duration with a probability of exceedance of 0.002 in 1 year (a return period of 500 years).
- We use this figure as basement design is considered to be critical.
- Figures and map available from BS EN 752:2008.

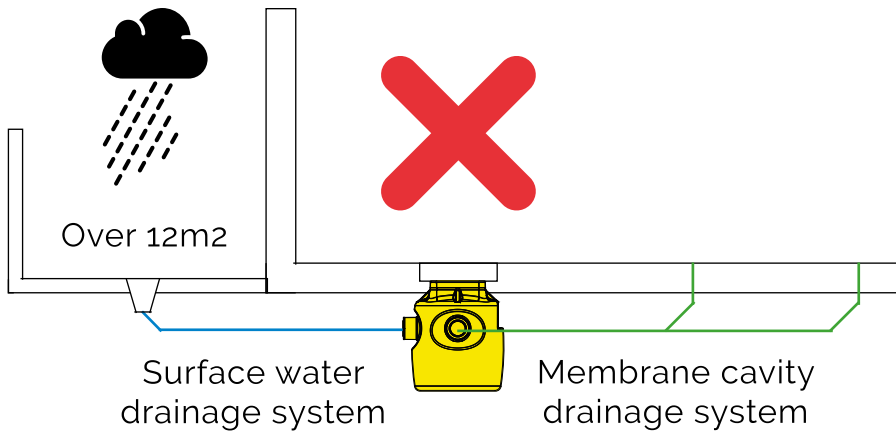

Pump station for a cavity system & external area MORE THAN 12m<sup>2</sup>

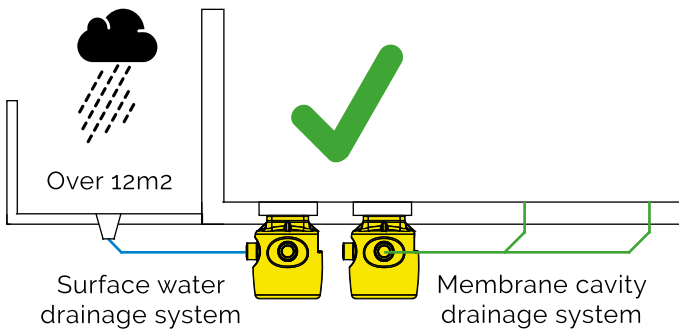

Pump stations for a cavity system & external area MORE THAN 12m<sup>2</sup>

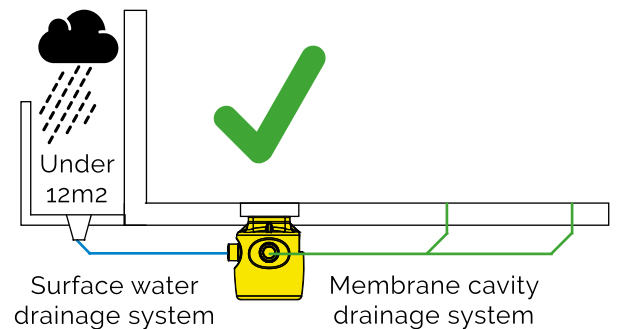

Pump station for a cavity system & external area NOT MORE THAN 12m<sup>2</sup>

# DUAL V3

A packaged pump station designed to collect ground water via perimeter channel or 110mm pipes (129 detail) and/or clear opening to the top of the chamber. This chamber cannot collect grey water from showers and wash hand basins, or foul from a WC (See 'Delta Foul V3 Sump'). A typical application would be collecting ground water from a basement up to 150m<sup>2</sup> and surface water from a 12m<sup>2</sup> lightwell.

The Dual V3 pump station has been specifically designed for below ground applications. The chamber is manufactured from HDPE and able to withstand hydrostatic forces encountered in applications with high water tables.

The pump station is delivered as a complete package including, chamber, all internal pipework and two powerful V3 pumps. It is designed to be installed by contractors with competent building, plumbing and electrical skills.

## PUMP STATION TECHNICAL DATA

DMS Code	DMS-164
Chamber Material	High Density Polyethylene
Volume Below Inlets	87L
Total Volume	217L
Fixed Inlets	3 x 110 / 160mm
Cable Duct Size	50mm
Discharge Connection	1.25" / 32mm BSP Class C
Discharge Pipework	1.25" / 32mm BSP Class C
Internal Pipework	1.25" / 32mm BSP Class C
Cable Duct Pipework	2" / 50mm White Waste Pipe

The Dual V3 is simple to install, the chamber sits on a concrete base, inlets in the form of perimeter channel or modular 110mm system are connected into the chamber, a 32mm discharge pipe connects to the gravity drain and a 50mm cable duct to bring electrics and control cabling from the chamber into a dry environment. The chamber is filled with water to prevent buoyancy and is surrounded with concrete. A simple rule of thumb is the top of the chamber should be level with the structural slab or no deeper than 500mm from the final finishes.

The installation is to be topped off with a double sealed cover supplied by the contractor to tie in with the general floor finish. Remember this product need to be accessed for service so care should be taken with its location.

For full installation instructions see 'Delta Dual V3 Installation Instructions' on our website.



## RECOMMENDATIONS

- AlertMaxx2 (DMS-298)
- PowerMaxx2 (DMS-280-1)

## SPECIFICATION

- NBS specification R18 (clause 310) Pumping Stations & Pressure Pipelines.



DUAL V3 - DMS-164

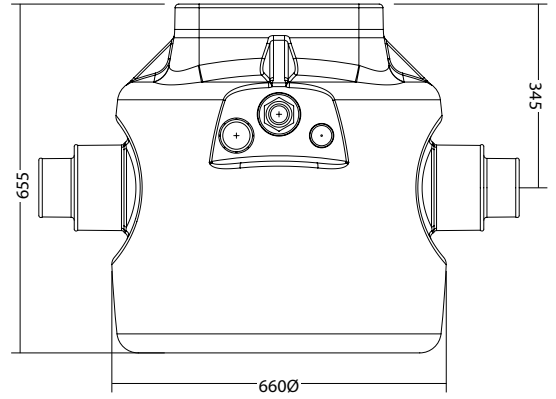
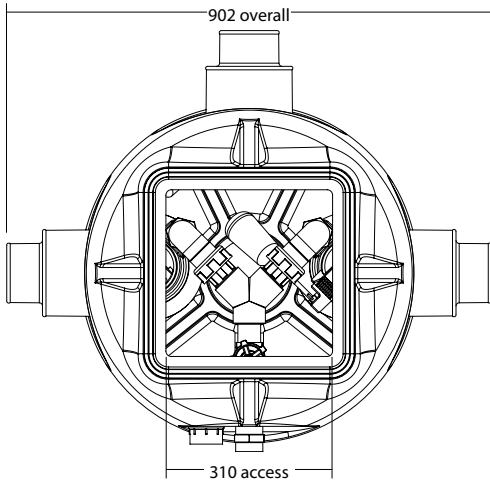

PUMP DATA

Pump Model	V3
Voltage	230V
KW Rating P1 / P2	0.43 / 0.18kW
Full Load Current	1.9A
Fuse Spur Rating	13A Non-switched
Typical Duty	2.0l/s @ 3.5m
Power Phase	Single
Weight	5.64kg

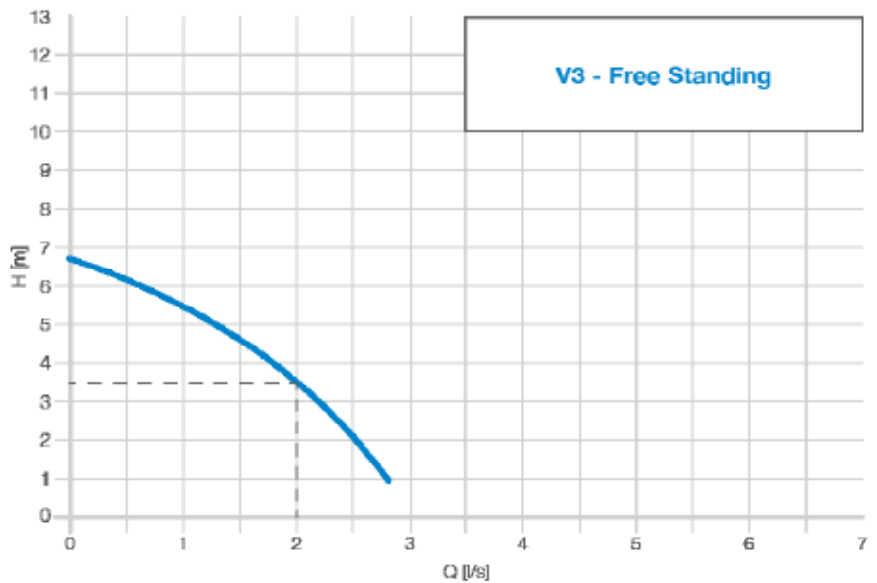

# DUAL V3.1

A packaged pump station designed to collect ground water via perimeter channel or 110mm pipes (129 detail) and/or clear opening to the top of the chamber. This chamber cannot collect grey water from showers and wash hand basins, or foul from a WC (See 'Delta Foul V3 Sump'). The Dual V3.1 is ideal for jobs where one or less inlet is required and space is limited. A typical application would be collecting ground water from a basement up to 150m<sup>2</sup> and surface water from a 12m<sup>2</sup> lightwell.

The Dual V3.1 pump station has been specifically designed for below ground applications. The chamber is manufactured from HDPE and able to withstand hydrostatic forces encountered in applications with high water tables.

The pump station is delivered as a complete package including, chamber, all internal pipework and two powerful V3 pumps. It is designed to be installed by contractors with competent building, plumbing and electrical skills.

## RECOMMENDATIONS

- AlertMaxx2 (DMS-298)
- PowerMaxx2 (DMS-280-1)

## SPECIFICATION

- NBS specification R18 (clause 310) Pumping Stations & Pressure Pipelines.

## PUMP STATION TECHNICAL DATA

DMS Code	DMS-166
Chamber Material	High Density Polyethylene
Volume Below Inlets	87L
Total Volume	217L
Fixed Inlets	1 x 110 / 160mm
Cable Duct Size	50mm
Discharge Connection	1.25" / 32mm BSP Class C
Discharge Pipework	1.25" / 32mm BSP Class C
Internal Pipework	1.25" / 32mm BSP Class C
Cable Duct Pipework	2" / 50mm White Waste Pipe

The Dual V3.1 is simple to install, the chamber sits on a concrete base, inlets in the form of perimeter channel or modular 110mm system are connected into the chamber, a 32mm discharge pipe connects to the gravity drain and a 50mm cable duct to bring electrics and control cabling from the chamber into a dry environment. The chamber is filled with water to prevent buoyancy and is surrounded with concrete. A simple rule of thumb is the top of the chamber should be level with the structural slab or no deeper than 500mm from the final finishes.

The installation is to be topped off with a double sealed cover supplied by the contractor to tie in with the general floor finish. Remember this product need to be accessed for service so care should be taken with its location.

For full installation instructions see 'Delta Dual V3 Installation Instructions' on our website.



DUAL V3.1 - DMS-166

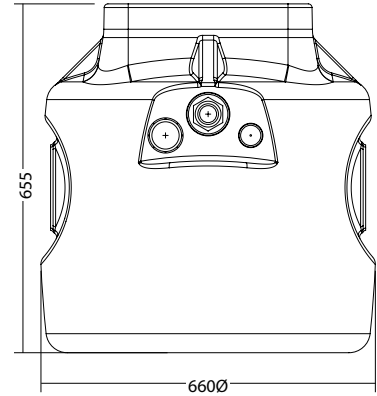
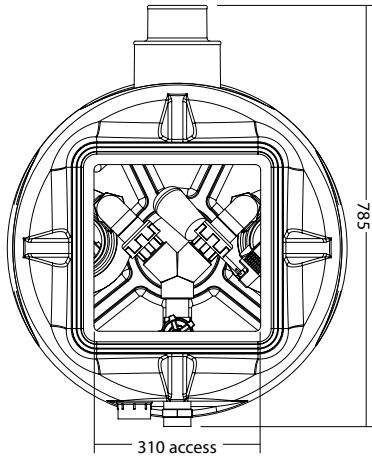

PUMP DATA

Pump Model	V3
Voltage	230V
KW Rating P1 / P2	0.43 / 0.18kW
Full Load Current	1.9A
Fuse Spur Rating	13A Non-switched
Typical Duty	2.0l/s @ 3.5m
Power Phase	Single
Weight	5.64kg

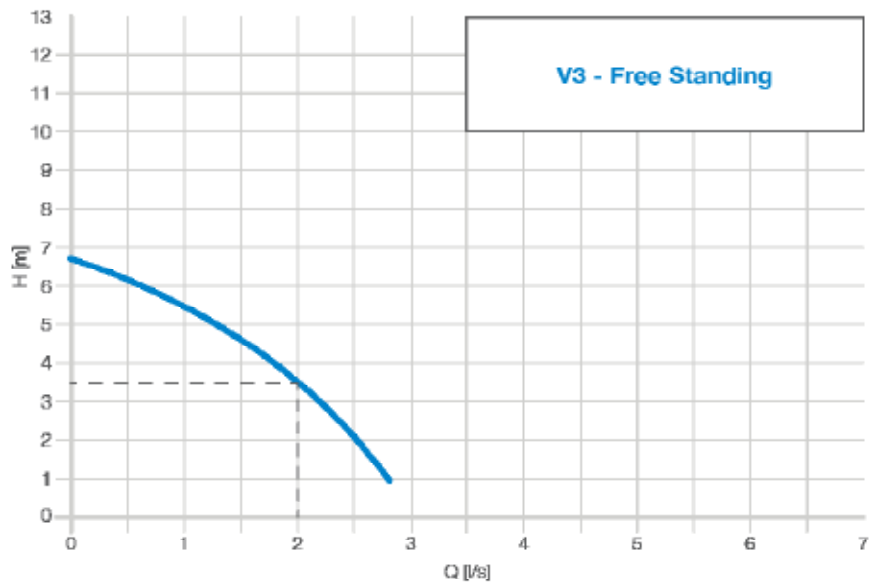

# DUAL V4

The Dual V4 is an upgrade to the standard Dual V3 where higher discharge heads are required. Typically, for double and triple depth basements or where long discharge runs are required resulting in higher than normal pipe work losses. The Dual V4 is suitable for basements that require a head height greater than the V3. The Dual V4 can pump 12m<sup>2</sup> of surface area in addition to ground water.

The Dual V4 has been specifically designed for below ground applications. The chamber is manufactured from HDPE and is able to withstand hydrostatic forces encountered in applications with high water tables.

The pump station is delivered as a complete package including chamber, all internal pipework and two powerful V4 pumps. It is designed to be installed by contractors with competent building, plumbing and electrical skills.

## RECOMMENDATIONS

- AlertMaxx2 (DMS-298)
- Hi-PowerMaxx (DMS-364)

## SPECIFICATION

- NBS specification R18 (clause 310) Pumping Stations & Pressure Pipelines.

## PUMP STATION TECHNICAL DATA

DMS Code	DMS-217
Chamber Material	High Density Polyethylene
Volume Below Inlets	137L
Total Volume	273L
Fixed Inlets	3 x 110 / 160mm
Cable Duct Size	50mm
Discharge Connection	2" / 50mm BSP Class C
Discharge Pipework	2" / 50mm BSP Class C
Internal Pipework	1.25" / 32mm BSP Class C
Cable Duct Pipework	2" / 50mm White Waste Pipe

The Dual V4 is simple to install, the chamber sits on a concrete base, inlets in the form of perimeter channel or modular 110mm system are connected into the chamber, a 32mm discharge pipe connects to the gravity drain and a 50mm cable duct to bring electrics and control cabling from the chamber into a dry environment. The chamber is filled with water to prevent buoyancy and is surrounded with concrete. A simple rule of thumb is the top of the chamber should be level with the structural slab or no deeper than 500mm from the final finishes.

The installation is to be topped off with a double sealed cover supplied by the contractor to tie in with the general floor finish. Remember this product need to be accessed for service so care should be taken with its location.

For full installation instructions, see 'Delta Dual V4/V6 Installation Instructions' on our website.



## DUAL V4 - DMS-217

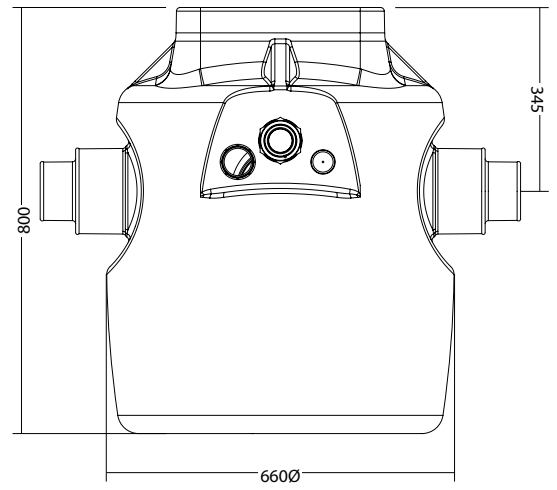
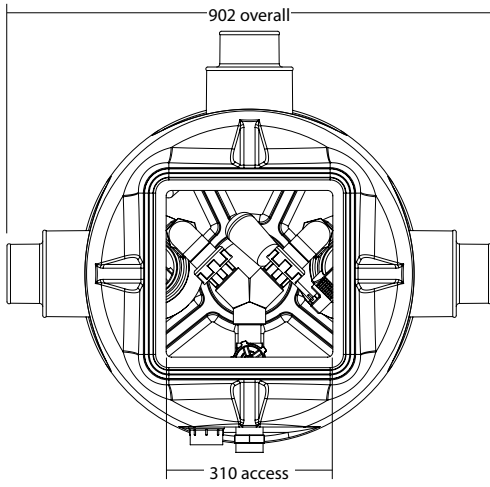

### PUMP DATA

Pump Model	V4
Voltage	230V
KW Rating P1 / P2	0.75 / 0.36kW
Full Load Current	4.0A
Fuse Spur Rating	13A Non-switched
Typical Duty	2.0l/s @ 7m
Power Phase	Single
Weight	6.7kg

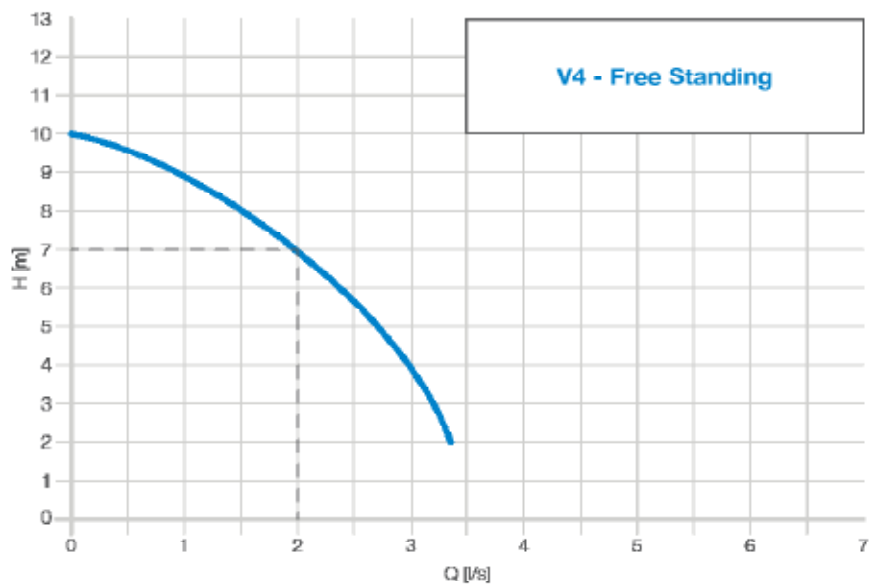

# DUAL V6

The Dual V6 is an upgrade to the standard Dual V3 where higher discharge heads are required. Typically, for double and triple depth basements or where long discharge runs are required resulting in higher than normal pipe work losses. The Dual V6 is suitable for basements that require a head height greater than the V4. The Dual V6 can pump 12m<sup>2</sup> of surface area in addition to ground water.

The Dual V6 has been specifically designed for below ground applications. The chamber is manufactured from HDPE and is able to withstand hydrostatic forces encountered in applications with high water tables.

The pump station is delivered as a complete package including chamber, all internal pipework and two powerful V6 pumps. It is designed to be installed by contractors with competent building, plumbing and electrical skills.

## RECOMMENDATIONS

- AlertMaxx2 (DMS-298)
- Hi-PowerMaxx (DMS-364)

## SPECIFICATION

- NBS specification R18 (clause 310) Pumping Stations & Pressure Pipelines.

## PUMP STATION TECHNICAL DATA

DMS Code	DMS-079
Chamber Material	High Density Polyethylene
Volume Below Inlets	137L
Total Volume	273L
Fixed Inlets	3 x 110 / 160mm
Cable Duct Size	50mm
Discharge Connection	2" / 50mm BSP Class C
Discharge Pipework	2" / 50mm BSP Class C
Internal Pipework	1.25" / 32mm BSP Class C
Cable Duct Pipework	2" / 50mm White Waste Pipe

The Dual V6 is simple to install, the chamber sits on a concrete base, inlets in the form of perimeter channel or modular 110mm system are connected into the chamber, a 32mm pipe discharge connects to the gravity drain and a 50mm cable duct to bring electrics and control cabling from the chamber into a dry environment. The chamber is filled with water to prevent buoyancy and is surrounded with concrete. A simple rule of thumb is the top of the chamber should be level with the structural slab or no deeper than 500mm from the final finishes.

The installation is to be topped off with a double sealed cover supplied by the contractor to tie in with the general floor finish. Remember this product need to be accessed for service so care should be taken with its location.

For full installation instructions, see 'Delta Dual V4/V6 Installation Instructions' on our website.





DUAL V4 / V6 - DMS-217 / 079

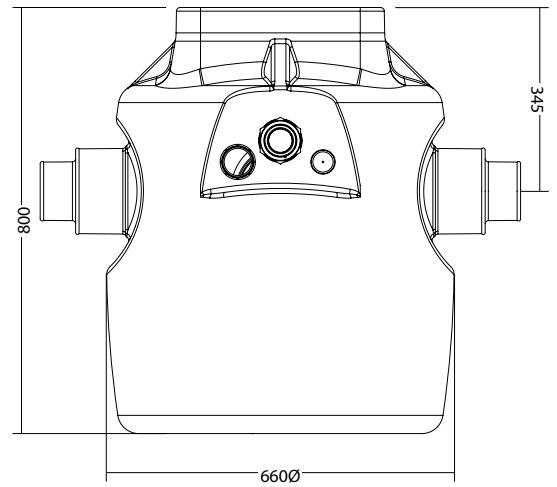
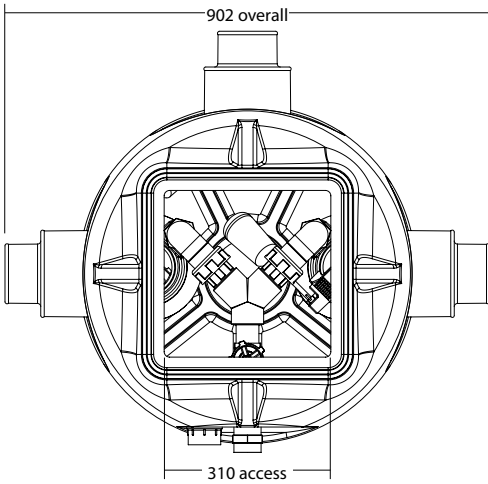

**PUMP DATA**

Pump Model	V6
Voltage	230V
KW Rating P1 / P2	1.05 / 0.50kW
Full Load Current	4.9A
Fuse Spur Rating	13A Non-switched
Typical Duty	2.0l/s @ 9m
Power Phase	Single
Weight	6.9kg

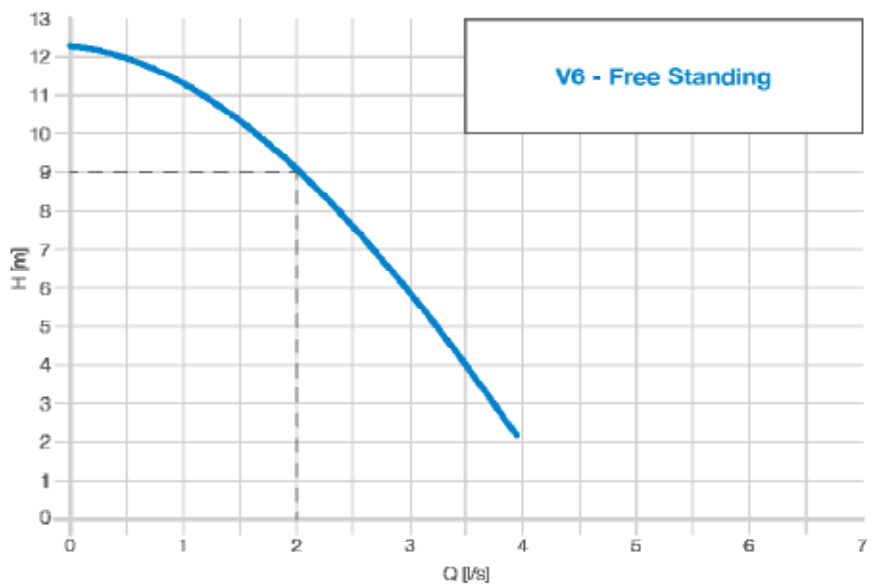

# 800 SERIES GROUND & SURFACE WATER STATIONS

The 800 series ground & surface water pump stations are available in depths from 800mm – 2000mm. Applications include collecting ground water from a Type C cavity membrane system or surface water from roofs and patios subject to selection criteria.

This product is specifically designed for below ground applications where hydrostatic water pressure may be present. However, they should be surrounded with concrete to prevent movement. A manhole cover is not supplied as these are generally site specific and installed in the final finish. However, if required the chamber will accept a standard 450mm x 600mm cover and frame. A kit is provided so inlets can be easily drilled and sealed on site in the positions highlighted in blue, making this product very simple to install.

The 800 series pump chambers are compatible with a range of free standing and guide rail mounted pumps.

## TYPICAL APPLICATION

- Ground Water
- Surface Water



## PUMP STATION TECHNICAL DATA

Chamber Model	800 Series
Chamber Material	High Density Polyethylene
Available Depths	800mm, 1000mm, 1300mm, 1500mm, 1800mm, 2000mm
Available Pumps	V3, V4, V6
Inlets	5 x 110mm grommets (supplied loose)
Cable Duct & Vent Size	50mm
Discharge Connection	BSP Class C
Cable Duct Pipework	2" / 50mm White Waste Pipe
Vent Pipework	2" / 50mm White Waste Pipe

## INLETS

Inlets can be cut on site using the inlet kit provided with the chamber. The sections highlighted in blue on the drawings below show the areas suitable for drilling inlets.

## SPECIFICATION

NBS specification R18 (clause 310)  
Pumping Stations & Pressure Pipelines.

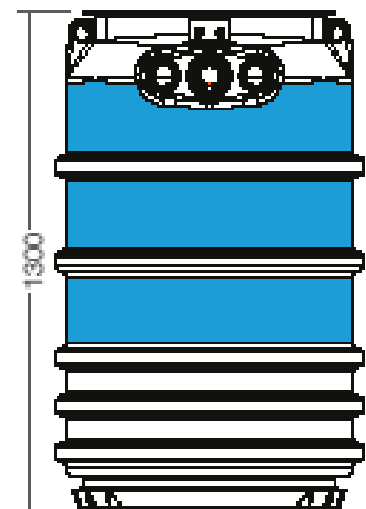
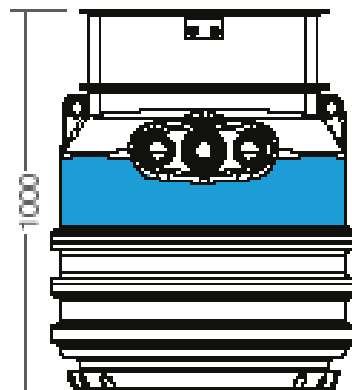
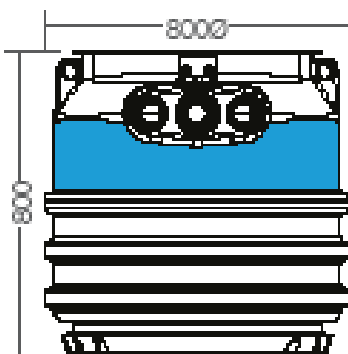

V3, V4, V6

50Hz - 1 - 230V Discharge 1.25" BSP Female					
Model	P1 kW	P2 kW	In A	Part No.	Weight Kg
V3	0.43	0.18	1.9	116	5.64
V4	0.75	0.36	4.0	216	7.17
V6	1.05	0.50	4.9	084	7.40

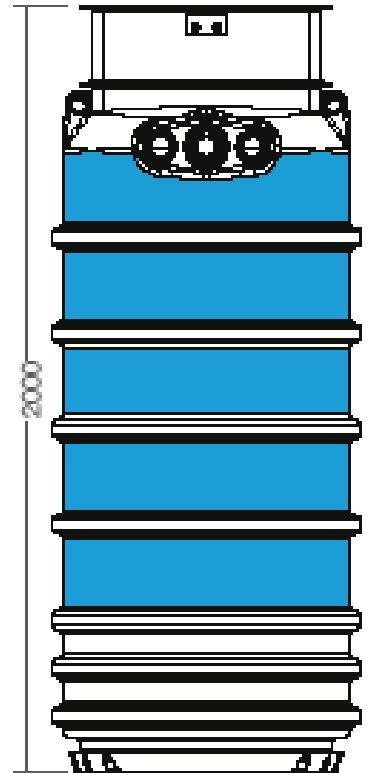
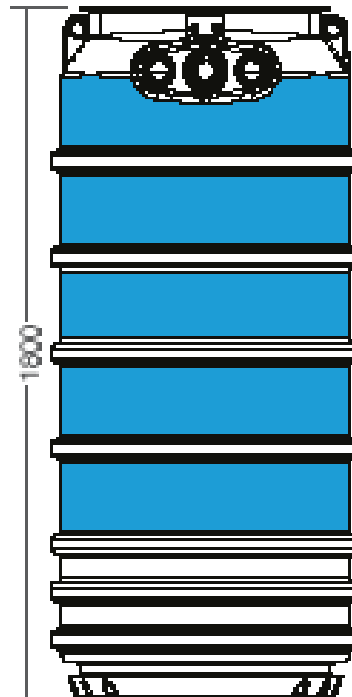
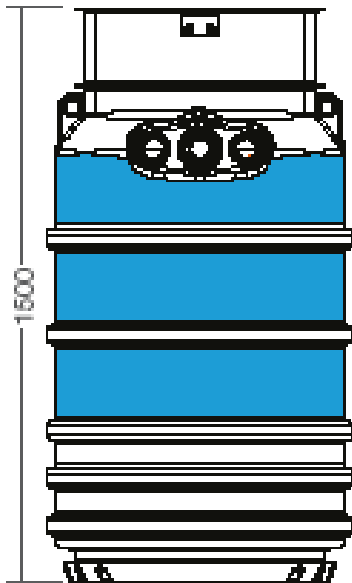
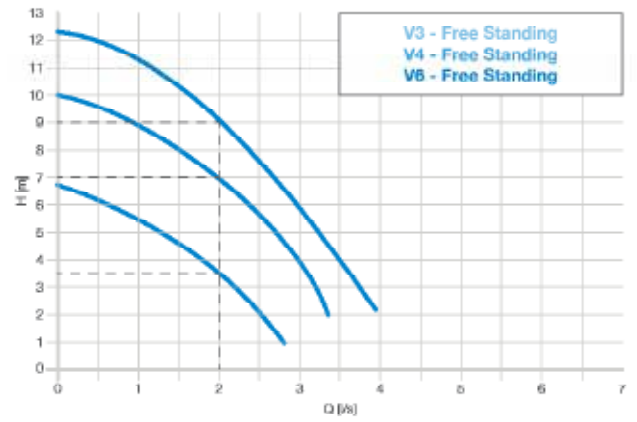

# 1000 SERIES GROUND & SURFACE WATER STATIONS

The 1000 series ground & surface water pump stations are available in depths from 1250mm - 3000mm. Applications include collecting ground water from a Type C cavity membrane system and larger surface water applications from roofs and patios subject to selection criteria.

This product is specifically designed for below ground applications where hydrostatic water pressure may be present. However, they should be surrounded with concrete to prevent movement. The chamber will accept a standard 750mm x 600mm cover and frame to suit floor build. A kit is provided so inlets can be easily drilled and sealed on site in the positions highlighted in blue, making this product very simple to install.

The 1000 series pump chambers are compatible with a range guide rail mounted pumps.

## TYPICAL APPLICATION

- Ground Water
- Surface Water

## INLETS

Inlets can be cut on site using the inlet kit provided with the chamber. The sections highlighted in blue on the drawings below show the areas suitable for drilling inlets.

## PUMP STATION TECHNICAL DATA

Chamber Model	1000 Series
Chamber Material	High Density Polyethylene
Available Depths	1250mm, 1500mm, 1750mm, 2000mm, 2250mm, 2500mm, 2750mm, 3000mm
Available Pumps	2500 Series, D10 Series
Inlets	5 x 110mm grommets (supplied loose)
Cable Duct & Vent Size	50mm
Discharge Connection	BSP Class C
Cable Duct Pipework	2" / 50mm White Waste Pipe
Vent Pipework	2" / 50mm White Waste Pipe

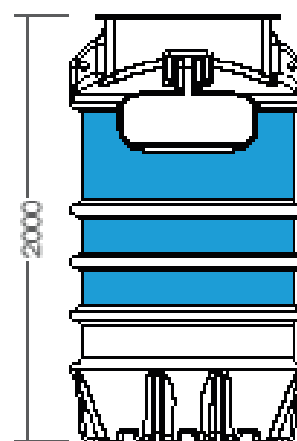
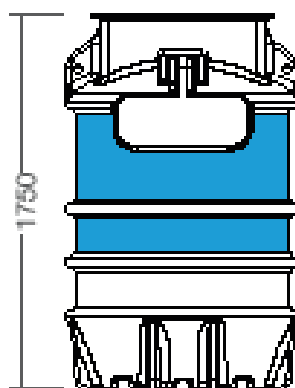
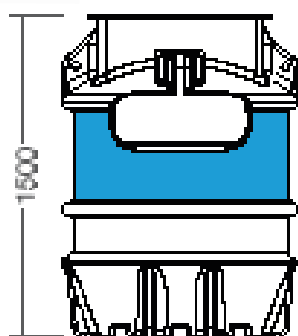
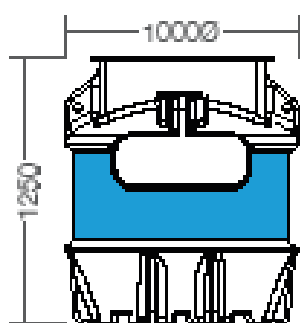

## 2500 SERIES

50Hz - 1 - 230V Discharge 2" BSP Female					
Model	P1 kW	P2 kW	In A	Part No.	Weight Kg
2500SA	1.00	0.55	5.0	Call	22
612SA	0.75	0.36	6.0	114	22
2502SA	1.05	0.50	8.2	PU-006	22
2503SA	1.90	1.10	8.2	PU-008	22
2500SM	1.00	0.55	5.0	Call	22
612SM	1.25	0.75	6.0	PU-005	22
2502SM	1.80	1.10	8.2	PU-007	22
2503SM	1.80	1.10	8.2	PU-009	22
50Hz - 3 - 400V Discharge 2" BSP Female					
2500TM	0.90	0.55	2.3	Call	22
612TM	1.10	0.75	2.8	Call	22
2502TM	1.50	1.10	3.0	Call	22
2503TM	2.05	1.50	3.5	Call	22

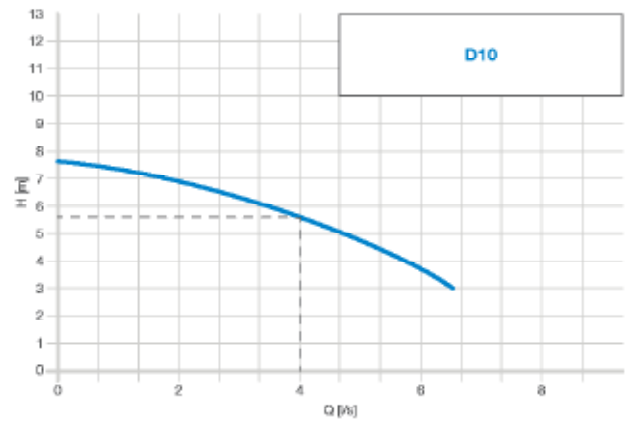
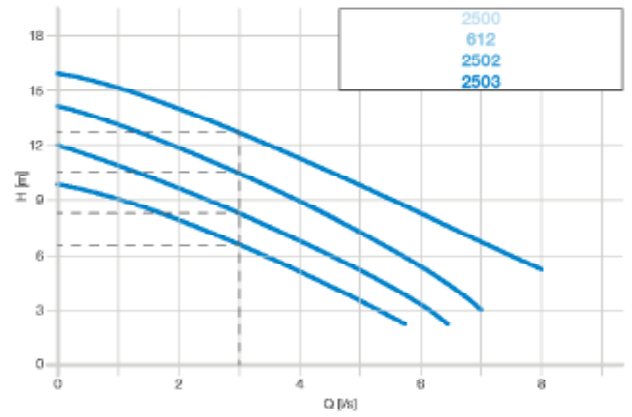

## D10 SERIES

50Hz - 1 - 230V Discharge 2" BSP Female					
Model	P1 kW	P2 kW	In A	Part No.	Weight Kg
D10SA	1.14	0.75	5.84	120	13.4
D10SM	1.14	0.75	5.84	PU-101	13.4

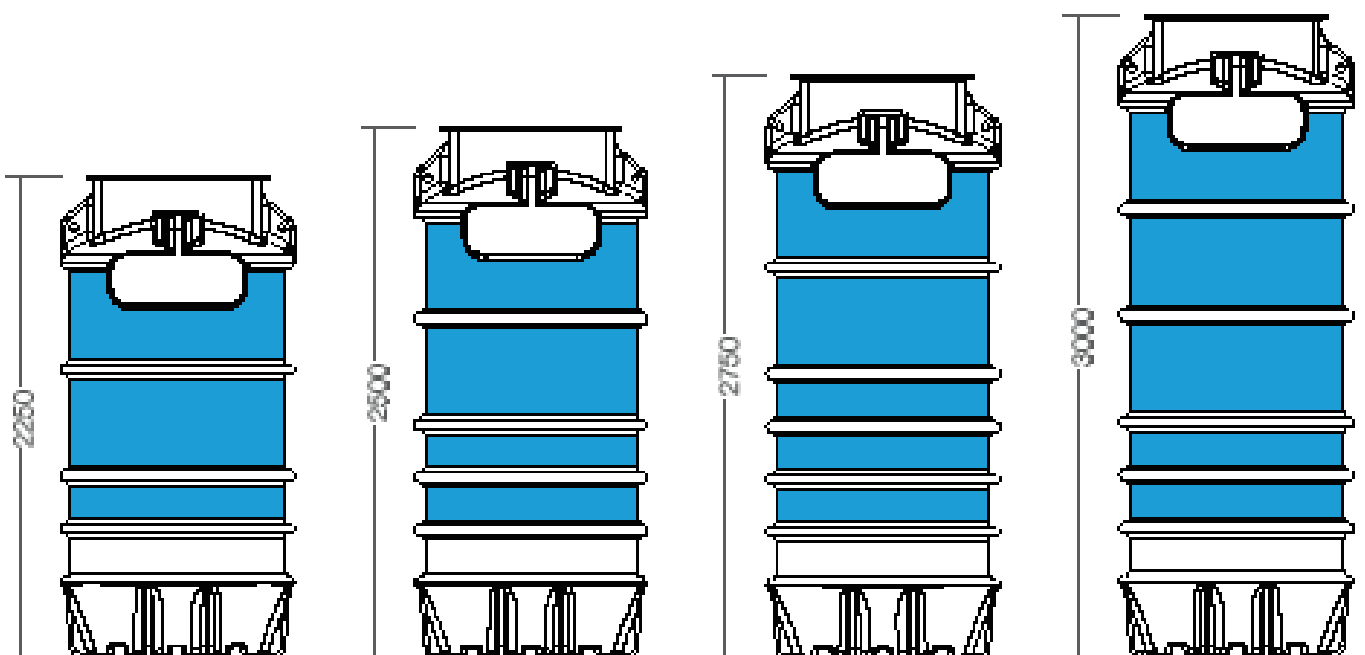

# FOUL WATER PUMP STATIONS

## FOUL WATER

A range of pump stations designed to collect foul water from a small utility room to large commercial projects, such as theatres, blocks of flats and major building upgrades where gravity discharge is not possible.

Our range of products have been designed specifically for these application and brings the technology of waterproofing and discharging water from properties under one responsibility, fully integrated and co-ordinated.



## CALCULATING FOUL WATER STORAGE VOLUMES

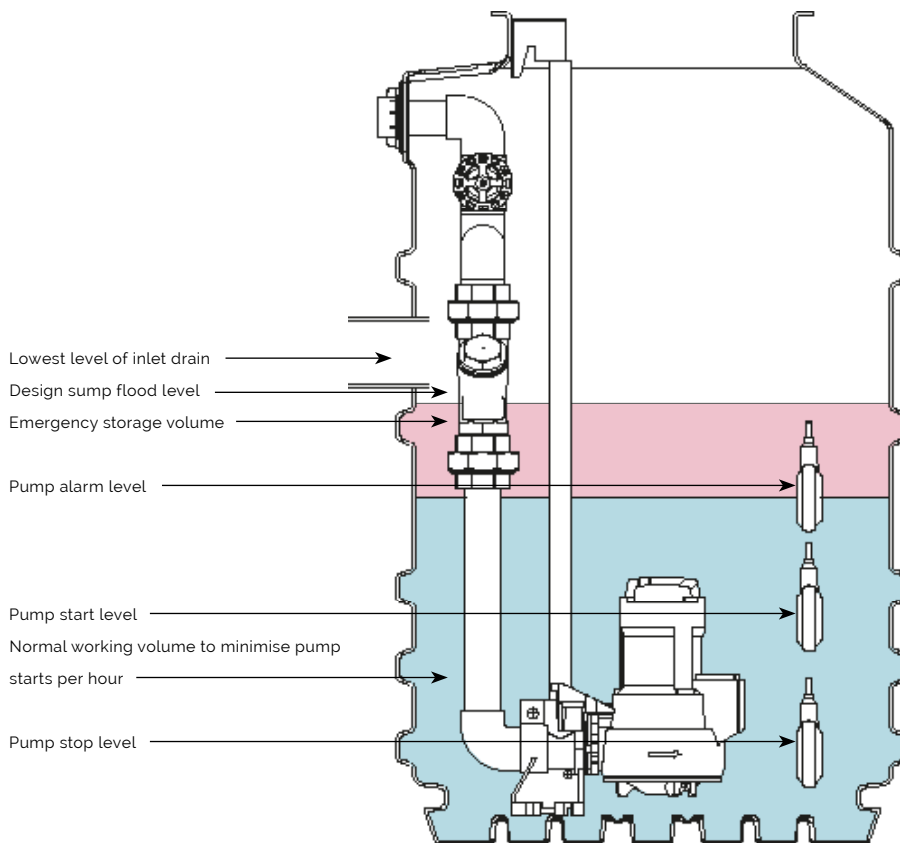

## NOTE

- The inlet drain should not be submerged otherwise there is a risk that the solid waste would cause a blockage.

## EMERGENCY STORAGE

- Where foul water drainage from a building is to be pumped, the effluent receiving chamber should be sized to contain 24 hour inflow to allow for disruption in service. The minimum daily discharge of foul drainage should be taken as 150 litres per head per day for domestic use. For other types of building, the capacity of the receiving chamber should be based on the calculated daily demand of the water intake for the building. Where only a proportion of the foul sewage is to be pumped, then the capacity should be based pro-rata. In all pump systems the controls should be so arranged to optimise pump operation.

Example : 6 bedroom house to be 'pumped' = 2 people in the master bedroom, 1 in each of the remaining =  $7 \times 150L = 1050L$

It is considered bad practice to pump facilities from ground level and above if they can be designed to be discharged by gravity.

It may not be necessary to allow for storage capacity on a pro-rata basis for basement application where alternative gravity facilities are available in accordance with BS6465.

## FLOW RATES FROM DWELLINGS

Number of dwellings	Flow rate (litres/sec)
1	2.5
5	3.5
10	4.1
15	4.6
20	5.1
25	5.4
30	5.8

## ASSESSING FOUL SUMP FLOW RATE

- The flow rate of a foul pump should equal or exceed the design inflow of the drainage system.
- For typical dwellings, where there is no information about the sanitary appliances, it is acceptable to use the information from the table opposite.
- For non-typical dwellings or where the sanitary appliances are known, the Delta Wastewater Design Flow Calculator can be used.
- For buildings other than dwellings, assistance from a Delta Consultant should be sought.

## VENTILATION OF FOUL SUMPS

- The purpose of sump ventilation is to;
  - a) allow foul gas to escape safely.
  - b) prevent the pump from overheating.
  - c) allow the sump to fill higher than normal in an emergency situation.
- The best situation is to provide a 50mm vent pipe connected directly to the sump at high level using the connection provided by the manufacturer.
- In some situations it is acceptable to ventilate the sump via the drainage system.
- The use of an air admittance valve is not acceptable.

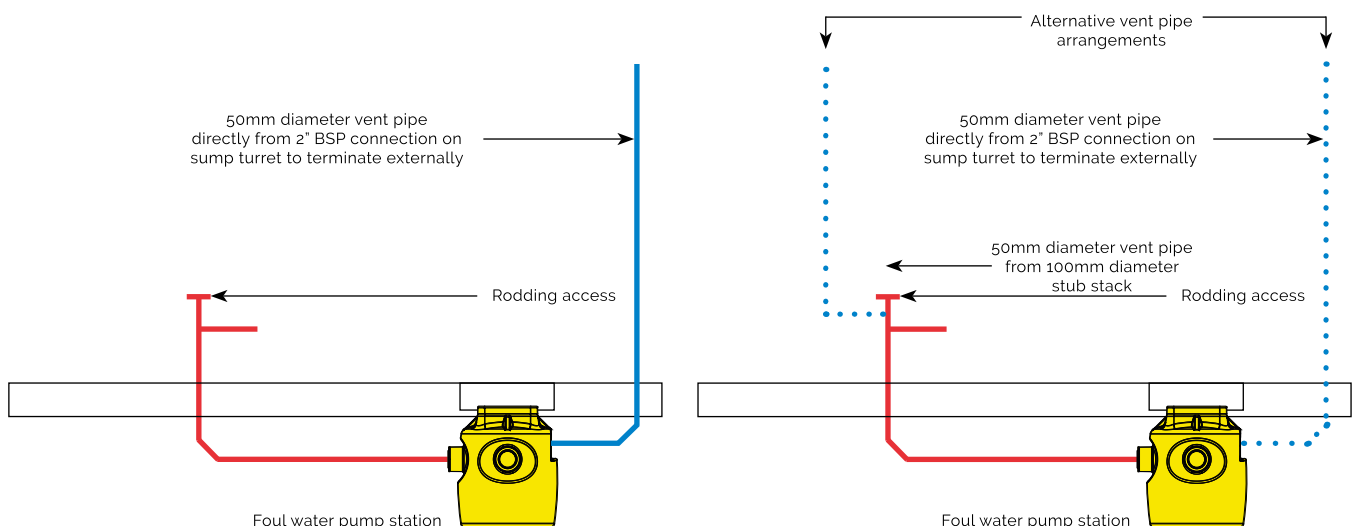
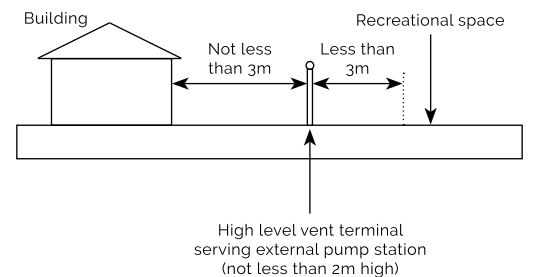
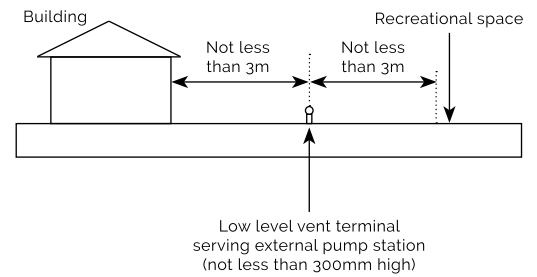
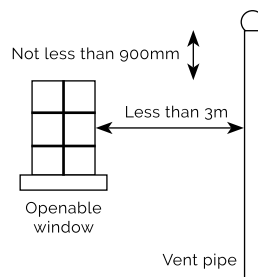

# FOUL V3

A packaged pump station designed to collect foul water from basements and ground floor extensions where other facilities in the property discharge via gravity. A typical application would be the collection and discharge of foul water from a basement fitted with a bathroom and a utility room. This pump station is not designed to collect ground water from a cavity membrane system (see Dual V3 Sump). For kitchen applications, we recommend fitting a grease trap prior to the pump station and do not recommend sinks fitted with macerator type waste disposal units are connected to pump stations.

The Foul V3 pump station has been specifically designed for below ground applications. The chamber is manufactured from virgin tank grade HDPE and is able to withstand hydrostatic forces encountered in applications with high water tables.

The pump station is delivered as a complete package with all internal pipework and a D10SA foul vortex pump. It is designed to be installed by contractors with competent building, plumbing and electrical skills.

## RECOMMENDATIONS

- AlertMaxx2 (DMS-299)
- Hi-PowerMaxx-XL (DMS-236)

## SPECIFICATION

- NBS specification R18 (clause 310) Pumping Stations & Pressure Pipelines.

## PUMP STATION TECHNICAL DATA

DMS Code	DMS-165-1
Chamber Material	High Density Polyethylene
Volume Below Inlets	137L
Total Volume	273L
Fixed Inlets	3 x 110 / 160mm
Cable Duct & Vent Size	50mm
Discharge Connection	2" / 50mm BSP Class C
Discharge Pipework	2" / 50mm BSP Class C
Internal Pipework	2" / 50mm BSP Class C
Cable Duct Pipework	2" / 50mm White Waste Pipe
Vent Pipework	2" / 50mm White Waste Pipe

The Foul V3 is simple to install, the chamber is sited on a concrete base, inlets in the form of 110mm pipework are connected into the chamber, a 50mm discharge pipe connects to the gravity drain and a 50mm cable duct to bring electrics and control cabling from the chamber into a dry environment. The chamber is vented via a 50mm duct to the same standard as a traditional SVP. An air admittance or 'durgo' type valve should not be used. The chamber is filled with water to prevent buoyancy and is surrounded with concrete. A simple rule of thumb is the top of the chamber should be level with the structural slab or no deeper than 500mm from the final finishes.

The whole lot is topped off with a double sealed cover supplied by the contractor to tie in with the general floor finish. Remember this product need to be accessed for service so care should be taken with its location.

For full installation instructions see 'Delta Foul V3 Installation Instructions' on our website.





FOUL V3 - DMS-165-1

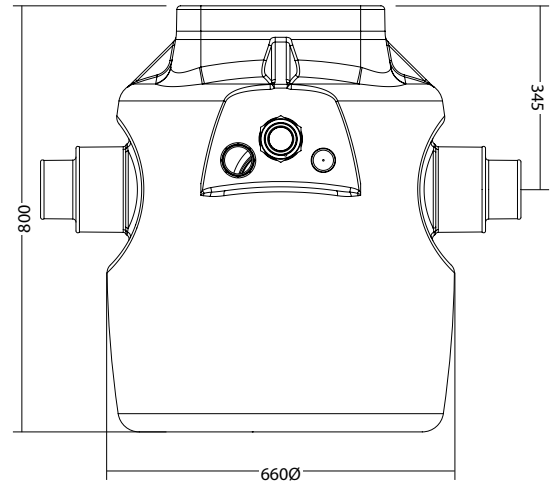
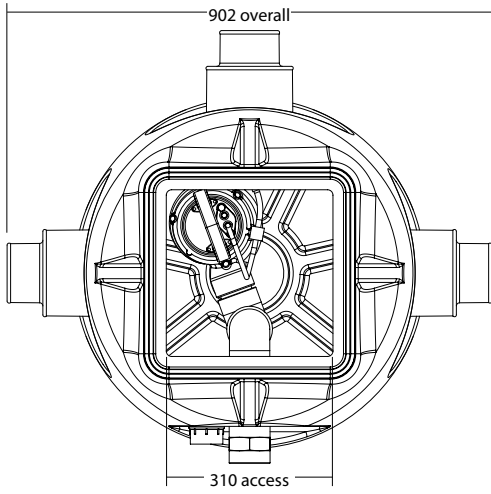

PUMP DATA

Pump Model	D10SA
Voltage	230V
KW Rating P1 / P2	1.14 / 0.75kW
Full Load Current	5.84A
Fuse Spur Rating	13A Non-switched
Typical Duty	4.0l/s @ 6.5m
Power Phase	Single
Weight	13.4kg

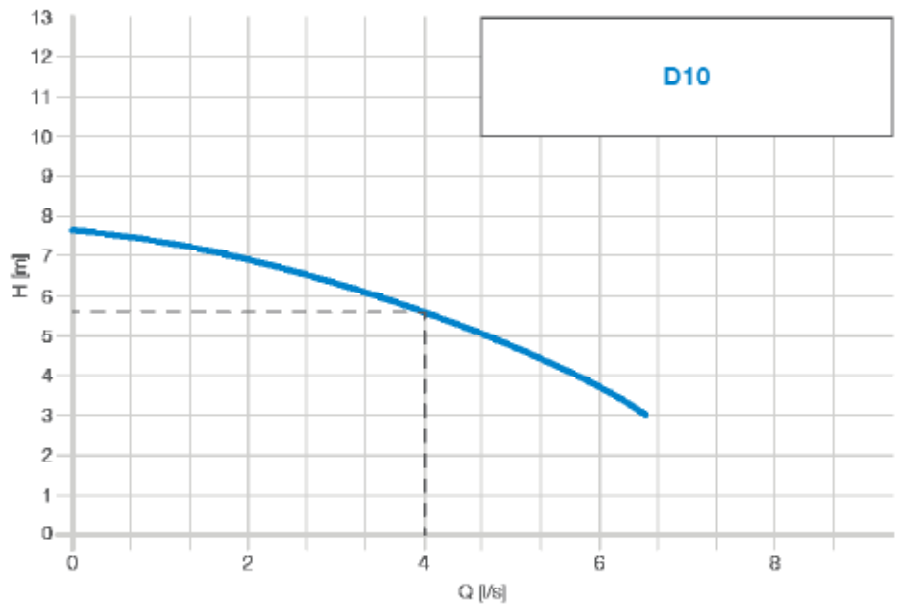

# 800 SERIES FOUL WATER STATIONS

The 800 series foul water pump stations are available in depths from 800mm - 2000mm. Applications include collecting foul and grey water from WC's, wash hand basins, showers, sinks and dishwashers subject to selection criteria, typically for larger self contained basements or where inverts are low due to site conditions. When the 800 series is collecting grey water from a kitchen, we recommend fitting a grease trap prior to the chamber to optimize the reliability of the pump station.

This product is specifically designed for below ground applications where hydrostatic water pressure may be present. However, they should be surrounded with concrete to prevent movement. A manhole cover is not supplied as these are generally site specific and installed in the final finish. However, if required the chamber will accept a standard 450mm x 600mm cover and frame.

The 800 series pump chambers are compatible with a range of free standing and guide rail mounted pumps.

**TYPICAL APPLICATION**

- Foul Water

**INLETS**

Inlets can be cut on site using the inlet kit provided with the chamber. The sections highlighted in blue on the drawings below show the areas suitable for drilling inlets.

## PUMP STATION TECHNICAL DATA

Chamber Model	800 Series
Chamber Material	High Density Polyethylene
Available Depths	800mm, 1000mm, 1300mm, 1500mm, 1800mm, 2000mm
Available Pumps	2500 Series, 2600 Series, D10 Series
Inlets	5 x 110mm grommets (supplied loose)
Cable Duct & Vent Size	50mm
Discharge Connection	BSP Class C
Cable Duct Pipework	2" / 50mm White Waste Pipe
Vent Pipework	2" / 50mm White Waste Pipe

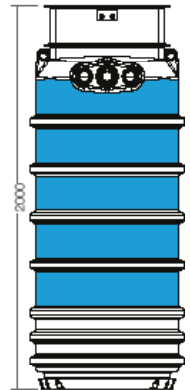
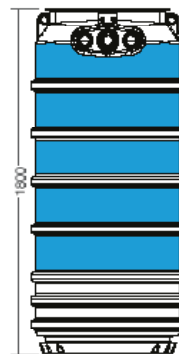
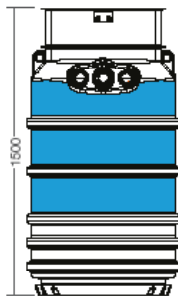
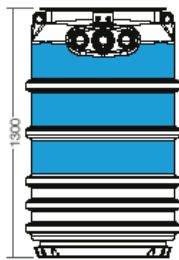
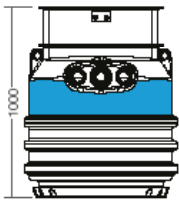
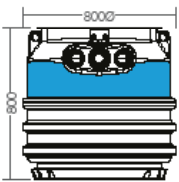

## 2500 SERIES

50Hz - 1 - 230V Discharge 2" BSP Female					
Model	P1 kW	P2 kW	In A	Part No.	Weight Kg
2500SA	1.00	0.55	5.0	Call	22
612SA	0.75	0.36	6.0	DMS-114	22
2502SA	1.05	0.50	8.2	PU-006	22
2503SA	1.90	1.10	8.2	PU-008	22
2500SM	1.00	0.55	5.0	Call	22
612SM	1.25	0.75	6.0	PU-005	22
2502SM	1.80	1.10	8.2	PU-007	22
2503SM	1.80	1.10	8.2	PU-009	22
50Hz - 3 - 400V Discharge 2" BSP Female					
2500TM	0.90	0.55	2.3	Call	22
612TM	1.10	0.75	2.8	Call	22
2502TM	1.50	1.10	3.0	Call	22
2503TM	2.05	1.50	3.5	Call	22

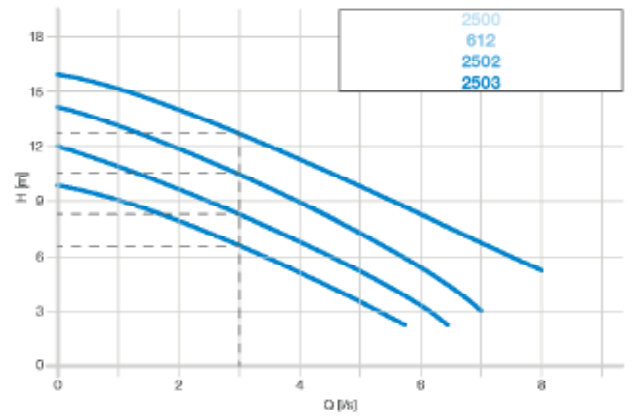

## 2600 SERIES

50Hz - 1 - 230V Discharge 2.50" BSP Female					
Model	P1 kW	P2 kW	In A	Part No.	Weight Kg
2601SA	1.25	0.75	6.0	PU-010	25
2602SA	1.80	1.10	8.2	PU-012	25
2603SA	1.80	1.10	8.2	PU-014	25
2601SM	1.25	0.75	6.0	PU-011	25
2602SM	1.80	1.10	8.2	PU-013	25
2603SM	1.80	1.10	8.2	PU-015	25
50Hz - 3 - 400V Discharge 2.50" BSP Female					
2601TM	1.10	0.75	2.8	Call	25
2602TM	1.50	1.10	3.0	Call	25
2603TM	2.05	1.50	3.5	Call	25

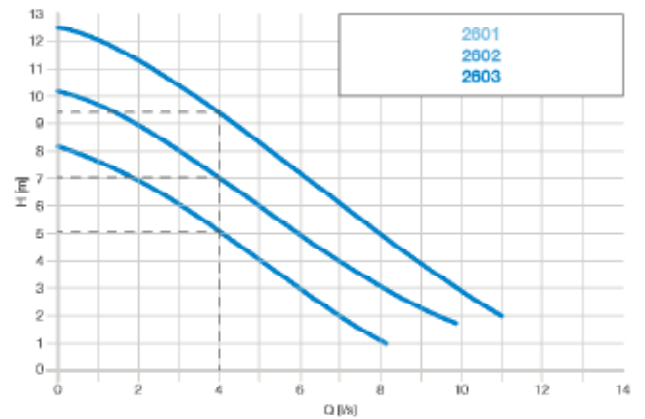

## D10 SERIES

50Hz - 1 - 230V Discharge 2" BSP Female					
Model	P1 kW	P2 kW	In A	Part No.	Weight Kg
D10SA	1.14	0.75	5.84	DMS-120	13.4
D10SM	1.14	0.75	5.84	PU-101	13.4

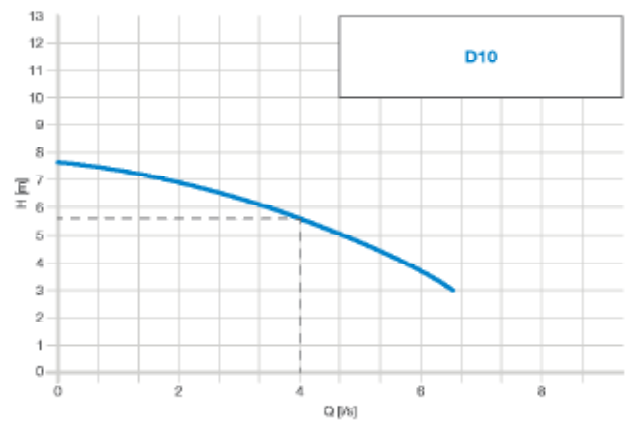

# 1000 SERIES FOUL WATER STATIONS

The 1000 series foul water pump stations are available in depths from 1250mm - 3000mm. Applications include collecting foul and grey water from WC's, wash hand basins, showers, sinks and dishwashers subject to selection criteria, typically for larger basements or where inverts are low due to site conditions. When the 1000 series is collecting grey water from a kitchen, we recommend fitting a grease trap prior to the chamber to optimize the reliability of the pump station.

This product is specifically designed for below ground applications where hydrostatic water pressure may be present. However, they should be surrounded with concrete to prevent movement. A manhole cover is not supplied as these are generally site specific and installed in the final finish. However, if required the chamber will accept a standard 450mm x 600mm cover and frame.

The 1000 series pump chambers are compatible with a range of free standing and guide rail mounted pumps.

## TYPICAL APPLICATION

- Foul Water

## INLETS

Inlets can be cut on site using the inlet kit provided with the chamber. The sections highlighted in blue on the drawings below show the areas suitable for drilling inlets.

## PUMP STATION TECHNICAL DATA

Chamber Model	1000 Series
Chamber Material	High Density Polyethylene
Available Depths	1250mm, 1500mm, 1750mm, 2000mm, 2250mm, 2500mm, 2750mm, 3000mm
Available Pumps	2500 Series, 2600 Series, D10 Series
Inlets	5 x 110mm grommets (supplied loose)
Cable Duct & Vent Size	50mm
Discharge Connection	BSP Class C
Cable Duct Pipework	2" / 50mm White Waste Pipe
Vent Pipework	2" / 50mm White Waste Pipe

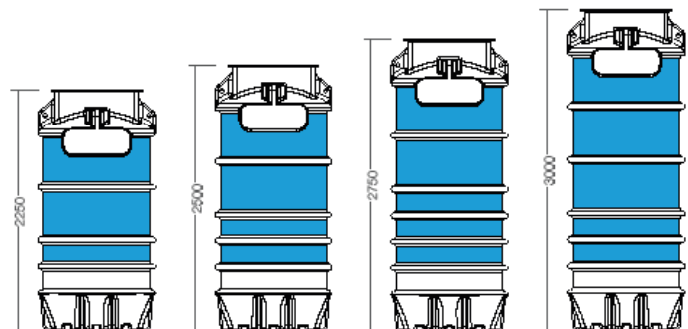
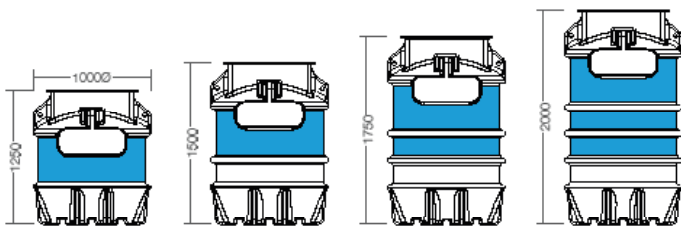

## 2500 SERIES

50Hz - 1 - 230V Discharge 2" BSP Female					
Model	P1 kW	P2 kW	In A	Part No.	Weight Kg
2500SA	1.00	0.55	5.0	Call	22
612SA	0.75	0.36	6.0	DMS-114	22
2502SA	1.05	0.50	8.2	PU-006	22
2503SA	1.90	1.10	8.2	PU-008	22
2500SM	1.00	0.55	5.0	Call	22
612SM	1.25	0.75	6.0	PU-005	22
2502SM	1.80	1.10	8.2	PU-007	22
2503SM	1.80	1.10	8.2	PU-009	22
50Hz - 3 - 400V Discharge 2" BSP Female					
2500TM	0.90	0.55	2.3	Call	22
612TM	1.10	0.75	2.8	Call	22
2502TM	1.50	1.10	3.0	Call	22
2503TM	2.05	1.50	3.5	Call	22

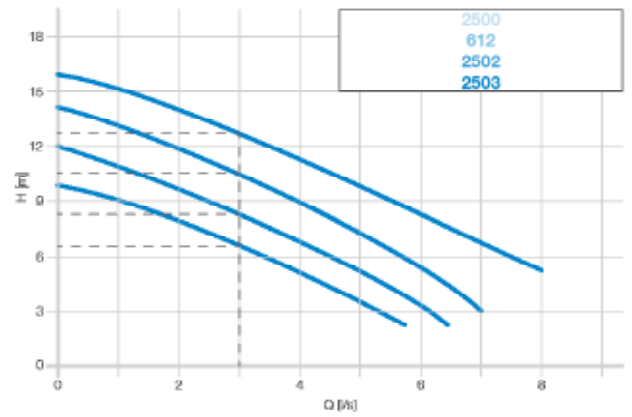

## 2600 SERIES

50Hz - 1 - 230V Discharge 2.50" BSP Female					
Model	P1 kW	P2 kW	In A	Part No.	Weight Kg
2601SA	1.25	0.75	6.0	PU-010	25
2602SA	1.80	1.10	8.2	PU-012	25
2603SA	1.80	1.10	8.2	PU-014	25
2601SM	1.25	0.75	6.0	PU-011	25
2602SM	1.80	1.10	8.2	PU-013	25
2603SM	1.80	1.10	8.2	PU-015	25
50Hz - 3 - 400V Discharge 2.50" BSP Female					
2601TM	1.10	0.75	2.8	Call	25
2602TM	1.50	1.10	3.0	Call	25
2603TM	2.05	1.50	3.5	Call	25

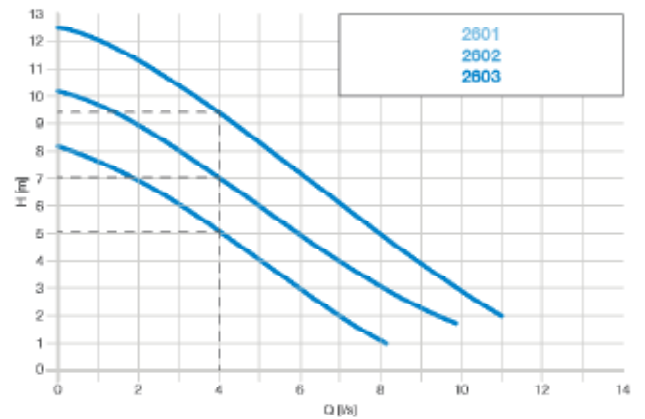

## D10 SERIES

50Hz - 1 - 230V Discharge 2" BSP Female					
Model	P1 kW	P2 kW	In A	Part No.	Weight Kg
D10SA	1.14	0.75	5.84	DMS-120	13.4
D10SM	1.14	0.75	5.84	PU-101	13.4

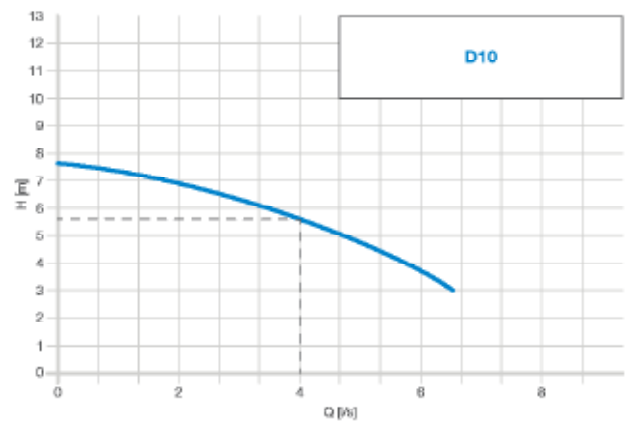

# ALERTMAXX2

The AlertMaxx2 is an intelligent high level alarm, designed to alert homeowners when the water level in their pump station becomes too high. AlertMaxx2 can be a stand alone high level alarm offering internal data logging, energy monitoring and a service reminder or it can be connected via Wi-Fi to the SideWinder Technology monitoring system ([www.sidewindertech.co.uk](http://www.sidewindertech.co.uk)). To enable the Wi-Fi, the AlertMaxx2 will have to be connected by one of the Certified SideWinder installers.

The AlertMaxx2 can be connected to a PowerMaxx or Hi-PowerMaxx. When connected, the AlertMaxx2 receives important data about the battery backups status and condition. The battery backup will also extend the operating time of the AlertMaxx2 during a power outage. All this data is transmitted via Wi-Fi (if connected) to the SideWinder operations centre where it is available 24/7 for intelligent analysis.

Offering a volt free contact, the AlertMaxx2 allows connection of external devices such as an alarm or beacon with a maximum load of 0.5A and voltage up to 30V. The VFR can also be connected to any BMS system if required for high level alarm only, sending a continuous signal.

## KEY FEATURES

- 6V battery backup.
- Intelligent logging.
- 100db sounder.
- Digital display.
- Software controlled.
- Local energy monitoring.
- Wi-Fi enabled.
- Predictive capabilities.
- 24 month component guarantee.

## TECHNICAL DATA

DMS Code (Ground Water / Foul Water)	DMS-298 / DMS-299
Size (without cable glands)	310mm x 170mm x 78mm
Weight (with battery installed)	1kg
Mains supply	200-250V AC (50Hz)
Internal battery	Pb 6V - 1.2Ah Lead Acid
Sounder	100db @ 30cm
Operating temperature	5-40°C
Power (standby)	<2W
IP	IP2X
Approximate installation time	1 hour
Electrical Requirements (Ground)	2 Spurs
Electrical Requirements (Foul)	1 Spur
Warranty	2 years



# LOOKING AFTER PROPERTIES WITH OUR VIRTUAL ENGINEER...

## INTELLIGENT LOGGING

Data from the property is uploaded and analysed by SideWinder Tech every 15 minutes.



## FLEXIBILITY

Can be connected to almost any single or dual pump system, both existing & new.



## ENERGY MONITORING

Provides local real time energy monitoring to show kWh usage per day.



## WI-FI ENABLED

Simple connection to the properties Wi-Fi network made by an approved SideWinder Tech installer.



## PREDICTIVE CAPABILITIES

Tells you before an event has happened! Predictive intelligence at it's best.



## INTERNAL BATTERY BACKUP

Alarms remain operational even when there is a power outage or tripped electrical circuit.

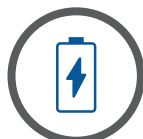

## 100DB SOUNDER

As loud as a chainsaw, the alarm will easily be heard throughout the entire property.



## MAXX BATTERY BACKUPS

Compatible with all Delta's range of battery backups. Battery status info uploaded to SideWinder Tech.



## DIGITAL DISPLAY

Shows current status and simple to understand fault codes.



## THE JOB OF THE VIRTUAL ENGINEER...

- Gives the property owner complete peace of mind.
- Detects over 70% of failures in advance, so an emergency becomes a scheduled visit.
- Detects pump blockages.
- Detects lime-scale build up.
- Creates triggers to investigate unusual events, i.e. longer or more frequent pump cycles.
- Understand more remotely than an engineer based at the property 24/7/365.

# POWERMAXX2

PowerMaxx2 is specifically designed for pump applications. It can run 2 x V3 (not simultaneously) ground water pumps without mains power for up to 15 days depending on the number of cycles/day and is virtually inaudible. 1 or 2 pumps are directly fed through the PowerMaxx2. If a power failure occurs, the pump/s automatically take power from the PowerMaxx2 which will have been fully charged during mains operation.

The PowerMaxx2 will automatically recharge when mains power returns. Installation is simple. The PowerMaxx2 is free standing and can be installed in any dry ventilated area. As this unit is fitted in the power line, no additional electrical spurs are required. The PowerMaxx2 is part of the MaxxConnect family and can operate as a stand alone unit or can be used in conjunction with AlertMaxx2. It can also be used as a direct replacement for previous versions.

## TECHNICAL DATA

DMS Code	DMS-280-1
Size (without cable glands)	155mm x 425mm x 300mm
Weight (without battery installed)	6kg
Weight (with battery installed)	19g
Mains supply	200-250V AC (50Hz)
Internal battery	24V - 1x22 Ah VRLA
Power (standby)	<3W
Power (charging)	75W
Peak Power Handling	600W P1
Visual display	2 x 7 segment
Operating temperature	5-35°C
Approximate installation time	30 minutes
Warranty	2 years

## KEY FEATURES

- Designed for 2 x V3 ground water pumps.
- Powers a V3 for up to 15 days
- Digital display to show status and comprehensive fault codes
- Configuration process to aid installation
- Dynamic Polling (DyPol) feature
- Compact quick charger facility
- 24 month component guarantee

## TOP TIP

Want longer run and standby times? A Hi-PowerMaxx or PowerMaxx XXL is available which has been designed to triple the available run and standby statistics of the PowerMaxx2.

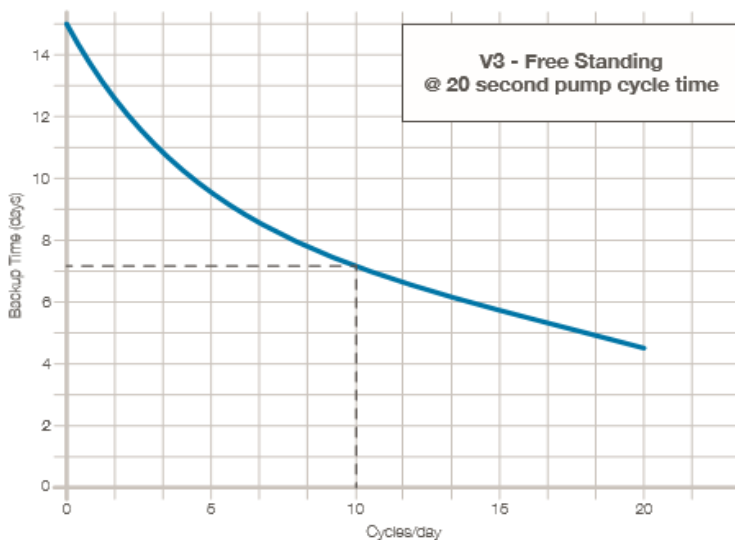

Mean average cycles/day = 10. Sample taken from 120 remote monitored ground water pump stations.





# HI-POWERMAXX

Hi-PowerMaxx is specifically designed for pump applications. It provides battery backup for larger pumps such as the V4 & V6, sits in standby mode for up to 50 days and is virtually inaudible. If a power failure occurs, the pump/s automatically take power from the Hi-PowerMaxx which will have been fully charged during mains operation.

The Hi-PowerMaxx will automatically recharge when mains power returns. Installation is simple, the Hi-PowerMaxx is free standing and can be installed in any dry ventilated area. As this unit is fitted in series between the spur and the pump, no additional electrical spurs are required. The Hi-PowerMaxx is part of the MaxxConnect family and can operate as a stand alone unit or can be used in conjunction with the AlertMaxx2. It can also be used as a direct replacement for previous versions.

## TECHNICAL DATA

DMS Code	DMS-364
Size (without cable glands)	475mm x 425mm x 300mm
Weight (without battery installed)	15.5kg
Weight (with battery installed)	80.5kg
Mains supply	200-250V AC (50Hz)
Internal battery	24V - 5x22Ah Lead Acid Total = 110Ah
Power (standby)	<3W
Power (charging)	55W
Peak Power Handling	2000W P1
Visual display	Red, Blue, Green LED
Operating temperature	5-35°C
Approximate installation time	1.5 hours
Warranty	2 years

## KEY FEATURES

- Designed for 2 x V4/V6 ground water pumps.
- Operates in standby mode during a power outage for at least 50 days.
- 24 month component guarantee.

## TOP TIP

The Hi-PowerMaxx can be used to backup manual pumps that run through a DUTY/STANDBY control panel (2000W max.). Please request a wiring diagram before attempting installation.

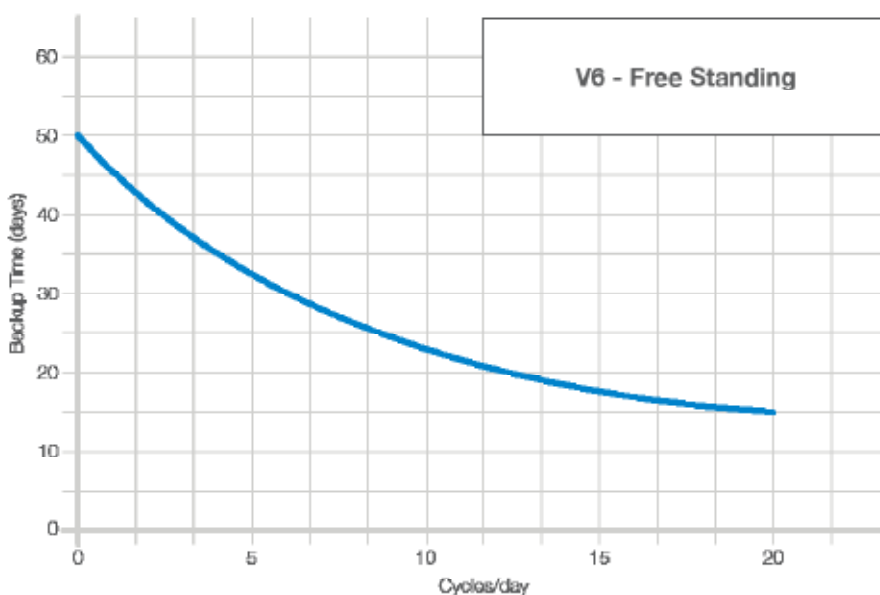

# ANCILLARY PRODUCTS & MAINTENANCE



## PIPE & FITTINGS

We can supply a range of pipe and pipe fittings from 1.25" up to 2.5". Our pipe and fittings are all high pressure PVC-U Class C with a pressure rating from 9 bar up to 15 bar depending on the type. We also stock high pressure solvent weld glue in 500ml pots.

## VALVES

We can supply a range of brass and cast iron valves including, swing check non return valves, non return ball valves and brass gate valves. Our valves range in size from 1.25" through to 2.50".

## PUMP & CHAMBER SPARES

We can supply a range of pump and sump spares. This includes float switches, replacement pump claws, cable harnesses, sounders & beacons and pipework assemblies. Please contact our technical team for more information.

## MAINTENANCE

Sump pumps must be maintained. We recommend a qualified engineer examines and services equipment every year. Pumps running frequently due to higher water tables, water drainage, or weather conditions should be examined more frequently, we recommend every 6 months. Sump pumps, being mechanical devices, may fail if not maintained which could lead to a flooded basement and costly repairs.

Regular servicing of sump pumps will increase efficiency and extend the life of the pump. All Delta Membrane pump systems can be maintained by our pump partners, Packaged Pump Systems (PPS) or the installing contractor.

## COMMISSIONING

All sump pumps require commissioning. Commissioning provides peace of mind, knowing that the system is installed correctly and in compliance with warranty conditions. When this is done by our pump partners Packaged Pump Systems (PPS), the warranty on the pumps is restarted from the date of commissioning.



# 'FREE LIME' RISK



The British Standard for waterproofing BS 8102:2009 recognises the requirement of a Type C Waterproofing System or Cavity Drain Membrane System to be maintainable.

The use of inspection ports within a Basement Waterproofing Design is key for maintenance or the ability to carry out periodic inspection. When new concrete is introduced to structures, there is a risk of excess free lime leaching out during the curing process in the form of calcium hydroxide, this free lime, if untreated, can enter the Cavity Drainage System which can impede the flow of water and cause sump pump failure. We recommend during a Cavity Drain System installation that a silicification pre-treatment of concrete be used to reduce the risk of free lime build up. Attention should be observed to dry pack joints often formed between the existing foundation and new concrete underpin, these are classic areas for free lime to infiltrate the structure and should be 'locked' down

## KOSTER POLYSIL-TG 500

An 'anti lime' coating product specially blended with Polymers and silicates which is applied by brush or spray application. Applying Koster Polysil-TG 500 will not only reduce the amount of free lime leaching into the Cavity Drainage System but will also improve the water resistance of the basement structure by absorption into the structure and locking in the free lime.



